

C. PARENT.  
Lathes for Turning Paper-Mill Rolls.

No. 196,593

Patented Oct. 30, 1877.

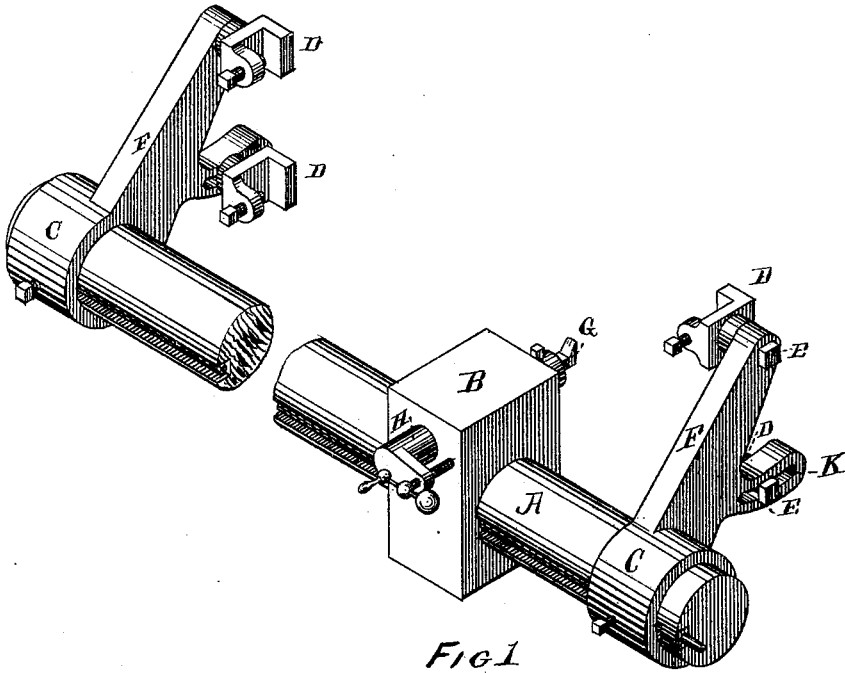

Fig 1

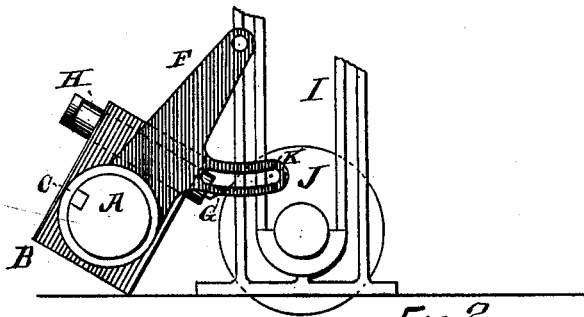

Fig 2

Witnesses  
John M. Woods  
W. H. Gray.

By

Caleb Parent  
Jas. W. See

Inventor

Attorney.

# UNITED STATES PATENT OFFICE.

CALEB PARENT, OF HAMILTON, OHIO.

## IMPROVEMENT IN LATHES FOR TURNING PAPER-MILL ROLLS.

Specification forming part of Letters Patent No. **196,593**, dated October 30, 1877; application filed June 29, 1877.

*To all whom it may concern:*

Be it known that I, CALEB PARENT, of Hamilton, Butler county, Ohio, have invented a new and useful Improvement in Lathes for Turning Paper-Mill Rolls, which improvement is fully set forth in the following specification and accompanying drawing, in which—

Figure 1 is a perspective view of my machine; and Fig. 2 is an end elevation of the same, showing its relation to the roll.

In paper-mills wooden rolls are frequently used to support the felt and to perform sundry pressing operations. These rolls must be round and smooth. When worn or damaged they are resurfaced in a lathe.

The object of my invention is to turn such rolls without removing them from their places, thus avoiding delay and expense.

My invention consists in so combining tool-holding, tool-guiding, and tool-feeding mechanism with the roll-housings that the roll may be turned while revolving in its own bearings.

In Fig. 1, A is a guide-rail, on which slides the tool-block B. The rail must be long enough to allow the block to have an unobstructed travel equal at least to the length of the roll-face.

The rail is shown as cylindrical in section, but may be of any section adapted to its functions, which are to support and guide the tool-block B. The feed may be effected by a screw or equivalent mechanism, and may be operated by hand, or by suitable connections by power, making the machine in the latter case automatic.

In practice I use a screw for feeding, and rotate the screw by means of open and crossed belt from the projecting end of the roll-shaft, in a manner not new and not needing description.

The tool-block B is provided with any suitable adjustable tool-holding device, as is usual with lathes.

If the rail be placed and firmly held parallel with a revolving roll, the tool G sliding along the rail in contact with the roll, it is obvious that the roll will be turned round if the roll-journals are round, and straight if the guide-rail is straight; but for obvious reasons it may be necessary to have such rolls crowning or spindle-shaped. The first effect is produced

by my machine by adjusting the rail so that it will not be parallel with the roll. This will, of course, cause the roll to be turned tapering, and tapering each end will, of course, produce the crown or camber desired. The amount of crownage is a matter of experience and judgment; but means for its attainment are provided, and will presently be described.

The spindle shape or circular crown is given to the roll by giving to the guide-rail a permanent bow or bend outward at the center.

It should be mentioned that such bend is in all cases so insignificant as to have no ill effect on other parts of the device.

In Fig. 2, J is the roll, and I one of its housings. This housing I find to be the most convenient part of the machine to which to attach the rail, though it may in cases be found best to attach it to the sole-plate, on which rests the housings. These housings are generally of iron, consisting of a vertical plate, with stiffening ribs or flanges.

Paper-mill machinery varies so little in this regard that a fair degree of adjustability in the connection between the housing and rail will adapt such connection to most any paper-machine.

I find that simply an extension of the means for making the taper adjustment before mentioned will allow adjustment for variations in style of housing and diameter of roll. I also find it most convenient to use the rib portion of the housing as the point of attachment, and have so devised the means of attachment that if these ribs are present no holes need be drilled in the housing, nor need they be cut or marred.

The clamps D, by means of the set-screws shown, are attached to the ribs mentioned, two on each housing, one above the other. Into the clamps are screwed the bolts E.

Each end of the rail is provided with a sleeve, C, having an arm, F. In the extremity of the arms are holes to fit the bolts of the upper clamps. The rail can thus be attached and suspended from the upper clamps, and may be swung in or out, as circumstances may allow or suggest.

A projecting segmental portion of the arm is provided with the slot K, which receives the bolt of the lower clamp, and furnishes

means of fastening the rail at any needed point. The rail is free within the sleeves C, and may be moved endwise or revolved to the proper position, and secured by the set-screws shown. These slots K allow the adjustment before spoken of, and also the adjustment for variation in size of roll.

Should it be found unobjectionable to drill the housings, or should the usual ribs be absent, the bolts E may pass into or through the housing, and the clamps D may then be dispensed with; or the arm F may be so shaped as to adapt it to any form of housing or sole-plate.

I consider a transverse sliding movement of the rail, made convenient by the use either of parallel slots in the arm or by sliding devices in the sleeves C, as equal to, in points of efficiency and in reality, the mechanical equivalents of the devices described for the purpose

of adjusting either or both ends of the rail with reference to the roll.

I should mention that I consider it very desirable to greatly increase the speed of the roll while being turned. In many paper-machines the means for doing this are present; in others it will be found necessary to make suitable arrangements for attaining increased speed.

I claim as my invention—

1. The combination of the tool-block B, guide-rail A, bracket-arms F, clamps D, and bolts E, substantially as and for the purpose specified.

2. The combination of the tool-block B, guide-rail A, and bracket-arms F, substantially as described.

CALEB PARENT.

Witnesses:

JAMES W. SEE,  
JOHN R. WOODS.